

# OPERATION INSTRUCTIONS

## V500 (Slave) Video Monitor

*\*Does not work as a standalone master\**

### Quick Guide

## Return to Stock

Product returns require a Return Merchandise Authorization Number(RMA). Please call customer service at 877-435-0670 to receive your RMA number, BEFORE returning any merchandise. Any product returned without an RMA number is subject of being refused and returned to customer. Once received Intrasonic Technology will evaluate the returned items for damaged and completeness. A credit memo will be issued to the customer once the product has been evaluated. Any damaged or missing items will be deducted from the amount credited. Return to stock items must be in unopened original boxes and in like new condition. Credit will not be issued for used or previously installed product. All returns are subject to a 10% restocking charge.

## Intrasonic Technology 2 Year Limited Warranty

Intrasonic Technology warrants its products to be free of manufacture defects for 2 years of closing or actual installation. This warranty only applies to products purchased from authorized dealers or distributors. If proof of installation cannot be supplied the manufactures serial number or date code will be substituted. This warranty extends to the original user or subsequent owner of the product during the warranty term. Intrasonic Technology will replace or repair the product at its discretion at no charge with a reconditioned or new product. All products with manufactured defects must be returned to Intrasonic Technology, Inc.

If an Intrasonic Technology product is determined to have a manufactures defect, please call our toll free number (877-435-0670) before any attempt to dismantle the product. Any attempts to dismantle the product will void the warranty.

An RMA (Returned Material Authorization) will be required prior to returning a product to Intrasonic Technology, Inc. To obtain an RMA call our toll free number (877-435-0670) and speak with a customer service representative. All products returned to Intrasonic Technology without an RMA will be refused.

Intrasonic Technology will not be liable for consequential, incidental or damages arising in connection with use or inability to use this product. In no event shall Intrasonic Technology liability hereunder exceed the cost of the product covered hereby. No person is authorized to assume for us or obligate us for any other liability in connection with the sale of this product. Some states do not allow the exclusion or limitation of consequential, incidental or damages, so the above limitation or exclusion may not apply. This limited warranty gives you specific legal rights, and you may also have other rights, which may vary state to state.

## Video Intercom

Warrants its products for two years of closing or actual installation. This warranty only applies to products purchased from authorized dealers or distributors. If proof of installation cannot be supplied the manufacture serial number or date code will be substituted. This warranty extends to the original user or subsequent owner of the product during the warranty term. Intrasonic Technology will replace or repair the product at its discretion at no charge with a reconditioned or new product. All products with manufactured defects must be returned to Intrasonic Technology, Inc.

## CARING FOR THE ENVIRONMENT BY RECYCLING



When you see this symbol on a product, do not dispose of the product with residential or commercial waste.

### Recycling your electrical equipment

Please do not dispose of this product with your residential or commercial waste. Some countries or regions, such as the European Union, have set up systems to collect and recycle electrical and electronic waste items. Contact your local authorities for information about practices established for your region.

## COPYRIGHT STATEMENT

All rights reserved. No part of this publication may be reproduced in any form or by any means, transcribed, translated into any language or computer language, transformed in any other way, stored in a retrieval system, or transmitted in any form or by any means, electronic, mechanical, recording, photocopying or otherwise, without the prior written permission of the owner.

# Accessories

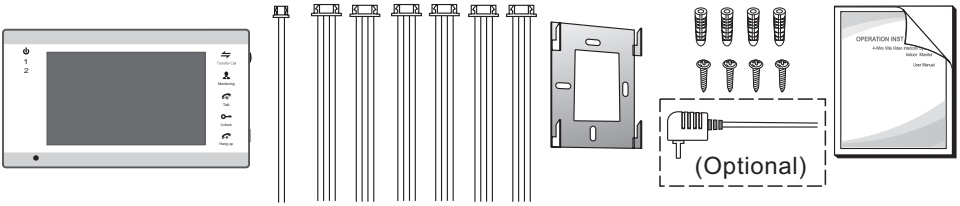

- Indoor monitor ----- 1pcs
- Screw anchors ----- 4pcs
- Wall screws ----- 4pcs
- Bracket ----- 1pcs
- 4 Pin line ----- 6pcs
- 2 Pin line ----- 1pcs
- User manual ----- 1pcs
- External switching power supply DC 12V(optional, please check actual model)-----1pcs

# Specification

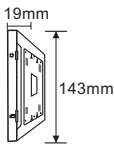
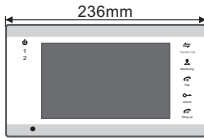

Display screen	7" TFT LCD screen
Definition	800 (H) X480 (V)
Standard	PAL/NTSC
Calling mode	Two-way conversation
Calling time	120s
Standby current	Maximum 200MA
Work current	Maximum 500MA
Power supply	Built-in power supply--optional
	External switching power supply(DC12V)--optional
Work temperature	-10°C~+60°C
Installation way	Surface mounting
Built-in storage	Yes
Picture format	JPEG standard format
Extension memory	SD card (maximum 32GB) (≥Class 10)

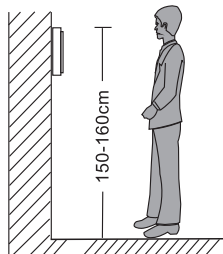

# Install the indoor monitor



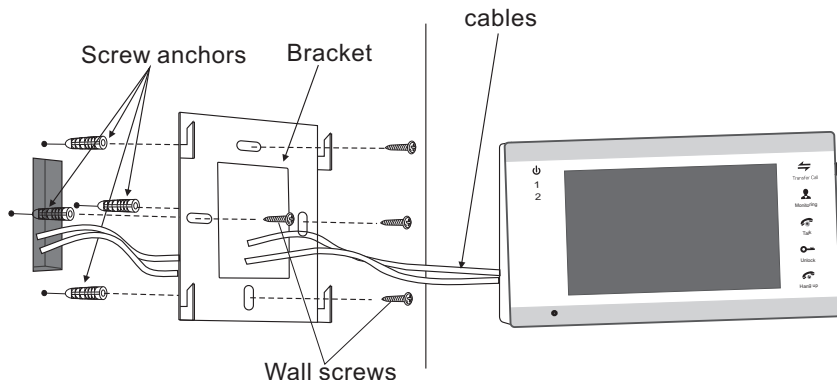

## How to install the indoor monitor?

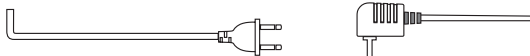

### NOTE ON WIRING CONNECTION

-  The electric lock/source/camera is not include in the package, you can purchase an electric lock that is suitable for your needs.
-  A standard relay mechanism supports locks with Normally Open (N.O.) door unlocking methods. This means that in the normal state the dry contact is opened so the lock is kept under constant closed state. If the unlocking push-button is pressed and the dry contact is changed to closed, then the lock is released.
-  The indoor monitor with a built-in power supply or an external switching power supply is optional, please refer to the manufacturer. The device with a built-in power supply is applicable to wide voltage range(AC 100V~240V). Please first pull out the AC power plug before installation of the device(shown below).



-  Please note the silk printing marked on PCB in order to avoid incorrect connecting.  
The wiring connection requirement:

1. 4C ordinary non-STP wiring cable;
2. Effective distance from the outdoor camera to furthest indoor monitor:
  - Transmission  $\leq 28\text{m}$  ( $4 \times 0.2\text{mm}^2$ )
  - Transmission  $\leq 50\text{m}$  ( $4 \times 0.3\text{mm}^2$ )
  - Transmission  $\leq 80\text{m}$  ( $4 \times 0.5\text{mm}^2$ )

**i** Wiring connection according to the following to avoid interference:

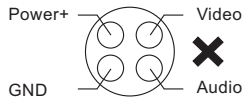
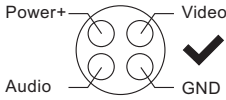

## WIRING DIAGRAM

# MUST ACTIVATE AS 'SLAVE' MONITOR IN MODE SETTINGS!!!

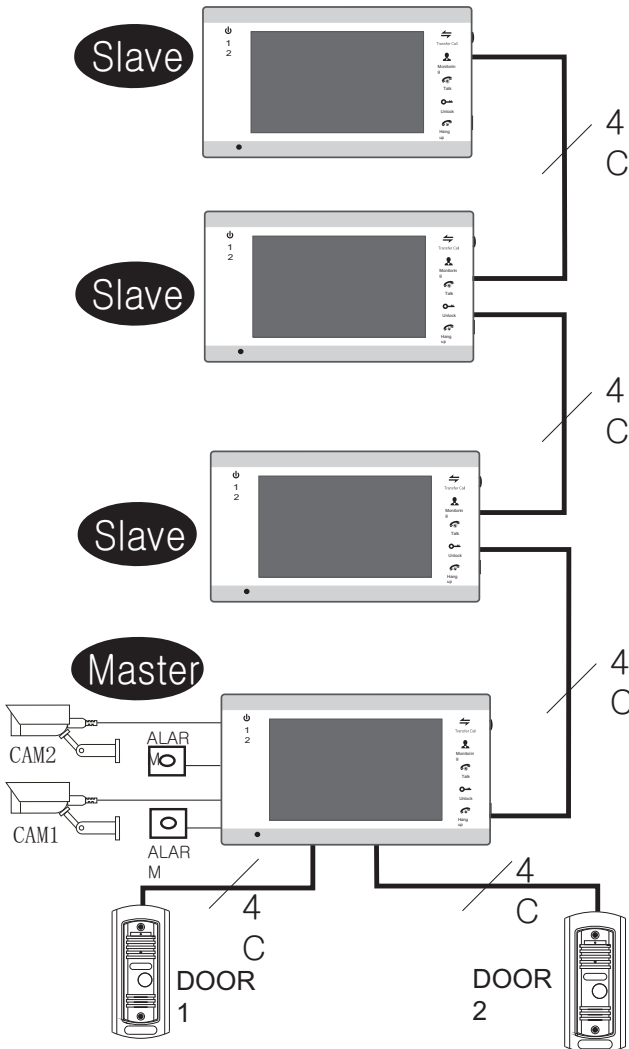

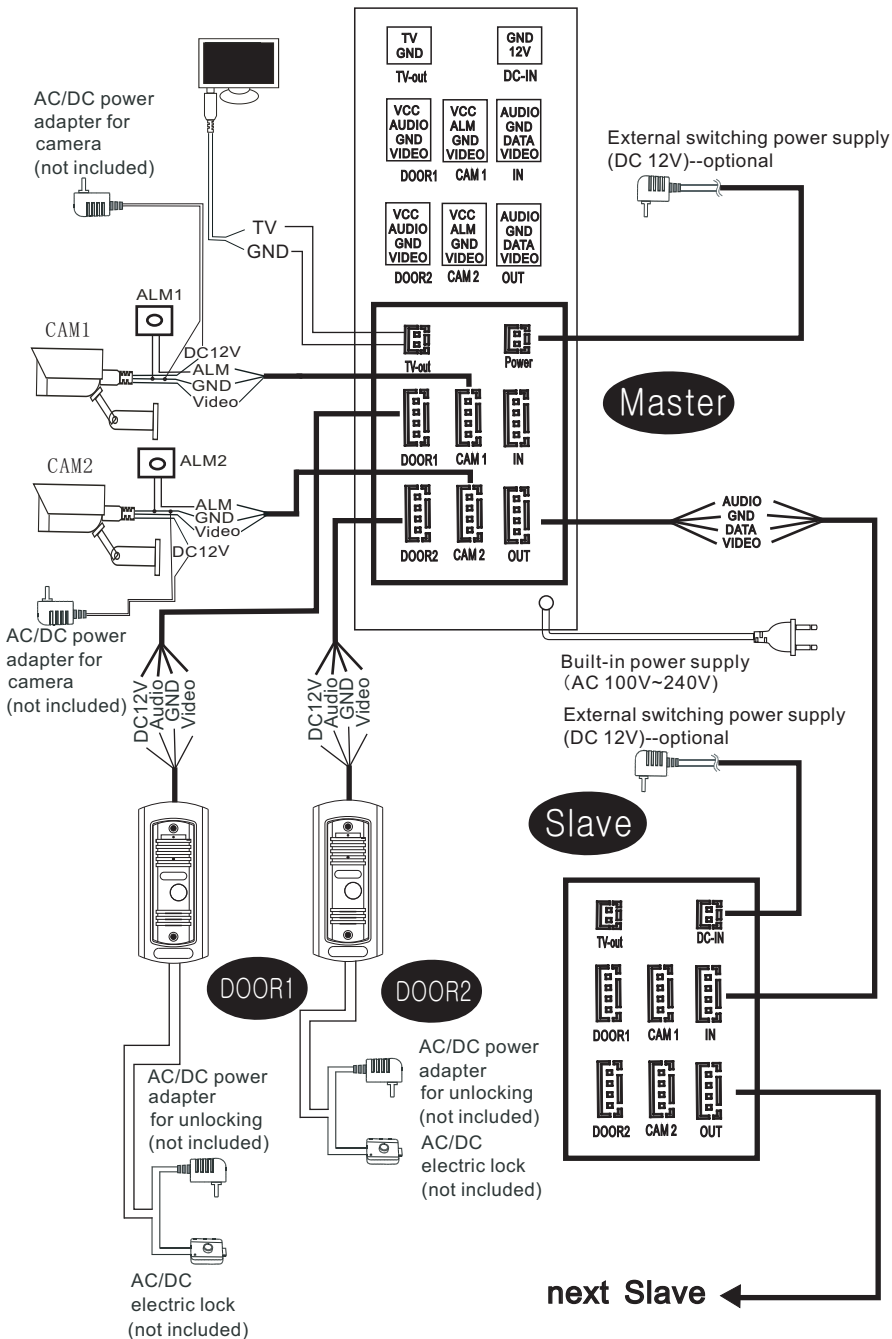

**Note:** For the indoor monitor with built-in power supply, the cameras must use an external power supply.

# DESCRIPTION ON INDOOR MONITOR

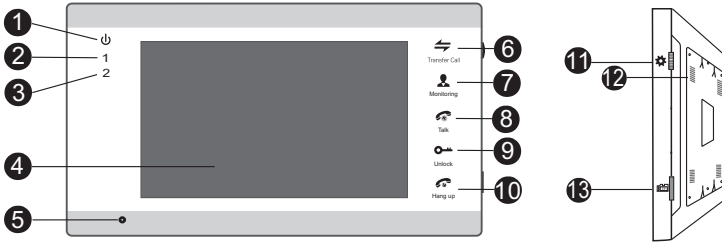

NO.	Name	Descriptions
1		Power LED, the power indicator of the indoor monitor.
2	<b>1</b>	The door 1 state lights, to door 1 working when the LED is on.
3	<b>2</b>	The door 2 state lights, to door 2 working when the LED is on.
4	TFT display	View visitor's image displayed on the TFT screen.
5	Microphone	Transmit the voice to outdoor camera.
6	 Transfer call	Intercom call or transfer calls to another indoor monitor.
7	 Monitoring	Watch the door and camera images.
8	 Talk	Activate conversation mode by pressing this button
9	 Unlock	Release the door lock.
10	 Hang up	Hang up
11	 Setting	<p>1. The button is a composite key, users can press the button, scroll the button upward or downward. For more details, please refer to the section "Menu Operations".</p> <p>2. In standby mode, press the button "⚙️" once to quickly access the menu.</p> <p>3. In main menu settings, scroll the button "⚙️" upwards or downwards to select sub-menu, then press "⚙️" again to enter sub-menu. In sub-menu settings, press "⚙️" to select menu options, scroll "⚙️" upwards or downwards to adjust values of each option, then press "⚙️" to confirm. When select option "Return" on the main menu, press "⚙️" to exit menu interface, and the indoor device will be into standby mode.</p>



NO.	Name	Descriptions
12	Speaker	Sound from outdoor camera.
13	TF card slot	For the models with SD card: insert the SD card for recording and pictures (supports up to 32GB). Recoding files will be stored in the SD card, photographs will be stored in the flash of the indoor monitor memory (on board). If the more than 20 pictures are saved to flash memory, those pictures will be backed-up to the SD card automatically when the indoor monitor is in standby mode.

## OPERATION INTRODUCTION

### ◆ VISITOR CALL

#### Standby mode

The Visitor press the **call** button on outdoor camera 1



10s of continuous ringing  
▼ tone is heard inside and outside

The Visitor press the **call** button on outdoor camera 2



The visitor's image automatically displayed on the screen

Press the **talk** button on indoor monitor



▼ Stop ringing

Start conversation with outdoor camera

▼ The conversation duration is 120s at a time

Press the **unlock** button on indoor monitor



release the door lock

Press the **hang up** button on indoor monitor



End

#### NOTICE:

The indoor unit will automatically go into standby mode if you are not at home or have not reached the indoor unit in 60s.

**i** Both the visitor's voice and image will continue to display for 20 seconds after the door has been unlocked. This is to ensure successful entry.

**i** For the models with SD card (when the doorbell starts recording): From the start of a call, the whole process will be recording. When the doorbell records for the snapshot mode, the first picture will be captured onto the built-in storage of the device

**i** In the monitoring state, the device can listen to the sound of the outdoor bell. The user can press the button “📞” to converse and press the button “🔑” to unlock.

## MONITORING

Option in the menu settings: DOOR1, CAM1, DOOR2, CAM2 operating mode (open or closed)

### Standby Mode

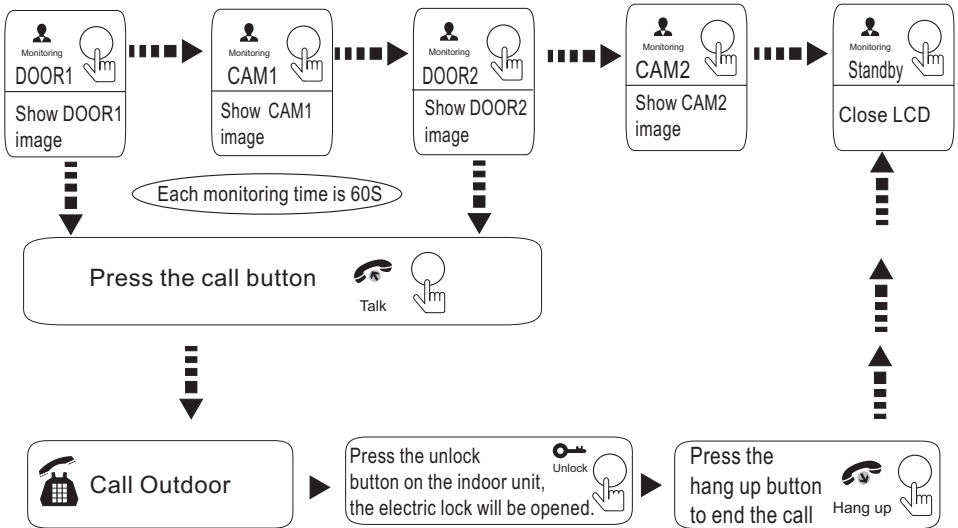

### NOTICE:

**i** If you are using only one outdoor camera in monitoring mode, you can also end the monitoring mode by pressing the monitoring button again (Must be Close CAM1; DOOR2; CAM2 in the menu option) .

**i** If a conversation with outdoor unit is underway in monitoring mode, a visitor can press the call button on either of outdoor units and the monitoring mode will be switched off. The visitor's image will then appear on its screen and continuous ringing will be heard. If you are using the indoor unit with hands-free, you can press the talking button to reactivate conversation with the visitor.

# CALL TRANSFER TO OTHER EXTENSION

Internal communication function requires at least two indoor and one outdoor units to be connected.

Outdoor camera call indoor monitor and conversation is underway



Press this button to activate the function of **call transfer to other extension**

▼ A continuous ringing tone is heard

Press the **talk** button on any indoor unit



Talking with visitor



The Electric lock can be opened



End the call and return to standby mode.



## NOTICE:

When you are transferring a call to other extension, the original conversation indoor unit will return to standby mode, and the indoor unit which the call is being transferred will also sound a continuous Ding Dong tone and the video image will appear on its screen.

# INTERNAL COMMUNICATION AMONG INDOOR UNITS

At least 2 indoor units are required.

## Standby Mode

Press the **Transfer Call** button



▼ A continuous ringing tone is heard

Press the **talk** button on any indoor unit



Start conversation among indoor units.



Press **Hang up** button



End

# MENU OPERATIONS

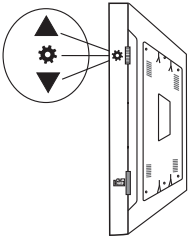

## NOTICE:

The button “⚙️” is a three-in-one key, but also composite keys: In standby mode, press the button “⚙️” once to enter the main menu settings. In main menu settings, scroll the button “⚙️” upwards or downwards to select sub-menu, then press “⚙️” again to enter sub-menu. In sub-menu settings, press “⚙️” to select menu options, scroll “⚙️” upwards or downwards to adjust values of each option, then press “⚙️” to confirm. When select option “Return” on main menu, press the button “⚙️” to exit menu interface, and the indoor device will be into standby mode.

If users don't do any operations or enter any interface on the indoor unit, the indoor device will go into standby mode after 1 minute automatically.

In standby mode \_ press the button “⚙️” to access the main menu interface ( to show the main interface as shown below). On menus \_ scroll “⚙️” upwards or downwards to move the cursor to the option “Return”, and then press \_ “⚙️” to exit.

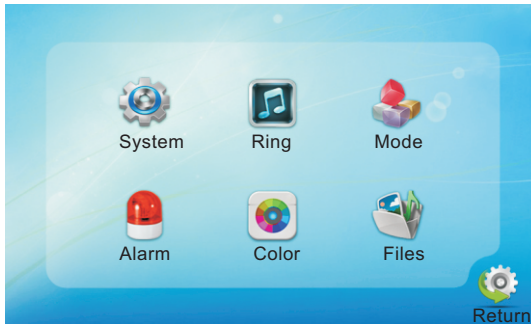

## 1. Set System Parameters

Scroll the button “⚙️” upwards or downwards to move the cursor to the option “System”, then press “⚙️” to enter the “System” menu. System setup includes: “Language”, “Time” and “Information”.

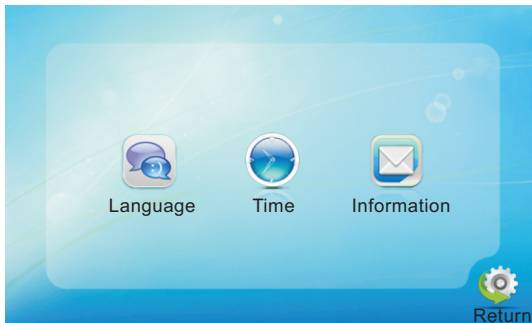

### 1.1 System – Language

On system menu, move the cursor to “Language” and press “⚙️” to enter the “Language” menu. Use this field to change the language of the machine menu text and the on-screen display. Press “⚙️” to select menu options, and then scroll “⚙️” upwards or downwards to adjust values, then press “⚙️” again to confirm.

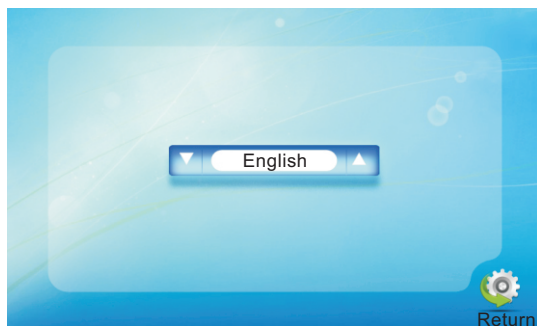

## 1.2 System – Time

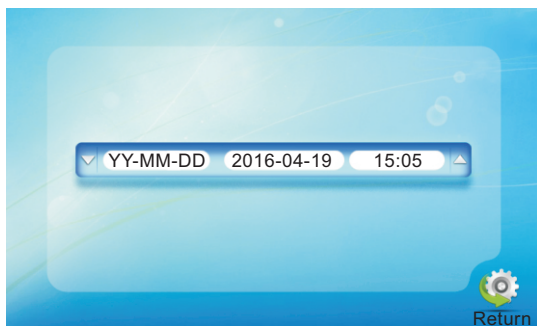

On system menu, move the cursor to “Time” and press “⚙️” to enter the “Time” menu. Use this field to switch the date format, include “YY-MM-DD”, “DD-MM-YY” and “MM-DD-YY”, to adjust system date and time. First scroll “⚙️” upwards or downwards to move the cursor, and press “⚙️” to select menu options, and then scroll “⚙️” upwards or downwards to adjust values, then press “⚙️” again to confirm.

## 1.3 System – Information

On system menu, move the cursor to “Information” and press “⚙️” to enter the “Information” menu. The information includes software version and release date.

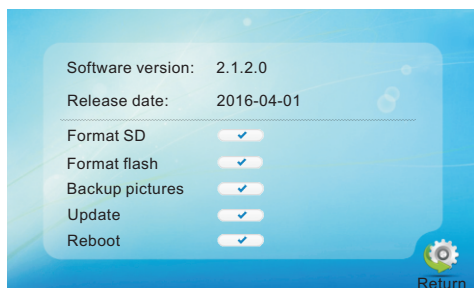

**[Format SD]:** This option is for the models with SD card. Format SD card, please format SD card firstly before using.



**Note:** The product only supports those SD cards more than Class10.

**[Format flash]:** This option is to format built-in storage of the indoor monitor.

**[Backup pictures]:** For the models with SD card \_ backup the photos on the built-in storage device to SD card manually, and the photos stored on the device will be deleted. The photos that backup onto the SD card need to be viewed on PC. (Plug SD card into PC to view)

**[Update]:** For the models with SD card, users can upgrade the firmware of the device via SD card.

**Note: During the system upgrading, don't remove the SD card or turn the indoor device off. After completing the upgrade, the device will restart.**

**[Reboot]:** Move the cursor to "  ", and press "  ". It will pop-up a window, choose "Yes" to restart the machine, choose "NO" to cancel.

**[Return]:** Exit the current menu.

## 2. Set the tone parameters

On main menu, move the cursor to the option "Ring", then press "  " to enter the "Ring" menu. Ring setup includes: "Ring select" and "Ring volume".

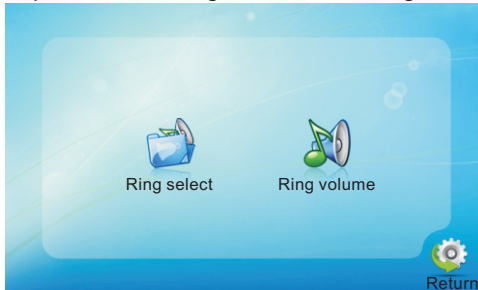

### 2.1 Ring – Ring select

On ring menu, move the cursor to "Ring select" and press "  " to enter the "Ring select" menu to set up the doorbell tone of the outdoor camera.

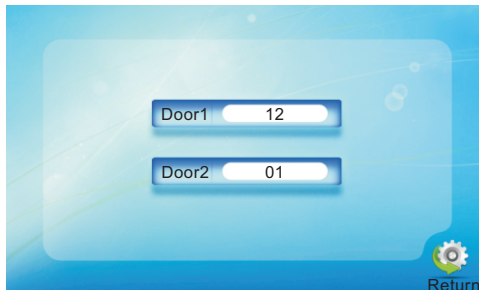

**[Door1]:** To set up the doorbell tone of the outdoor camera 1 (total of 12).

**[Door2]:** To set up the doorbell tone of the outdoor camera 2 (a total of 12).

**[Return]:** Exit the current menu.

### 2.2 Ring – Ring volume

On ring menu, move the cursor to "Ring volume" and press "  " to enter the "Ring volume" menu to set up the ring volume. Users can set up different ring volume during three different time period, the vibrate and ring time can be adjusted from 10s to 45s when calling.

**[Ring Vol1]:** the volume level of Ring Vol1: 00–10.

**[Ring Vol2]:** the volume level of Ring Vol2: 00–10.

**[Ring Vol3]:** the volume level of Ring Vol3: 00–10.



### 3. Set the mode of the indoor monitor

On main menu, move the cursor to the option “Mode”, then press “

A screenshot of a menu with a blue background and a white rounded rectangle containing the following text:

Mode:	Master
Door2 status:	On
Record mode:	Snapshot
Door1 unlock time:	02 Second
Door2 unlock time:	02 Second

In the bottom right corner, there is a gear icon and the word "Return".

**[Mode]:** Options include “Master” and “Slave”. “Master” indicates that the indoor unit connects the outdoors or cameras, “Slave” indicates that the indoor unit connects the main or sub indoor unit.

**[Door2 status]:** Enable or disable the preview of Door2.

**[Record mode]:** For the models with SD card, options include “Record” and “Snapshot”. “Record” indicates that the device with SD card will start record automatically when a visitor press the call button on the outdoor camera. “Snapshot” indicates that the device will capture a frame of the video stream as a still photo if a visitor press the call button on the outdoor camera.

**[Door1 Unlock Time]:** From 02 seconds to 10 seconds.

**[Door2 unlock time]:** From 02 seconds to 10 second.

**[Return]:** Exit the current menu.

#### 4. Set the alarm parameters

On main menu, move the cursor to the option “Alarm”, then press “⚙” to enter the “Alarm” menu.

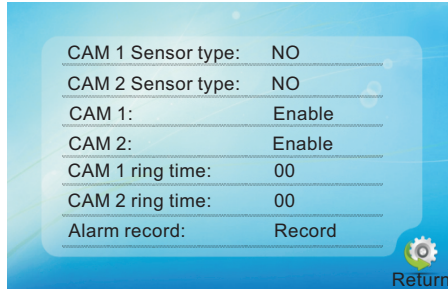

**[CAM 1 Sensor type or CAM 2 Sensor type]:** Each camera channel corresponds to an I/O status (see the following status explanations), which means that when an alarm is triggered, it will activate the corresponding channel to start alarm recording or capture a snapshot.

##### I/O status types:

**NO:** “Normally open” means that in its normal state, the sensor is kept under constant low voltage. If the output voltage changes from low to high, then the alarm will be triggered.

**NC:** “Normally closed”, the normal state of the sensor is under constant high voltage. If the output voltage changes from high to low, then the alarm will be triggered.

**Disable:** Set the sensor type to “Close”, if external sensor alarms are not in use.

**[CAM1]:** Enable or disable the preview of camera 1.

**[CAM2]:** Enable or disable the preview of camera 2.

**[CAM 1 ring time]:** The alarm ring time of camera 1, if camera 1 has been triggered by activity, (detected by the sensor) and the values can be set from 0~30 seconds.

**[CAM 2 ring time]:** The alarm ring time of camera 2, if camera 2 has been triggered by activity, (detected by the sensor) and the values can be set from 0~30 seconds.

**[Alarm record]:** Options include “Record” and “Snapshot”. “Record” indicates that when an alarm is triggered, it will activate the corresponding channel to start alarm recording. “Snapshot” indicates that when an alarm is triggered, it will activate the corresponding channel to capture a picture of the current video stream as a still photo.

**[Return]:** Exit the current menu.

#### 5. Set the color parameters

On main menu, move the cursor to the option “Color”, then press “⚙” to enter the “color” menu.



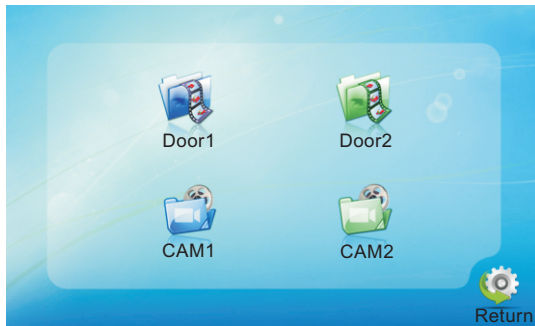

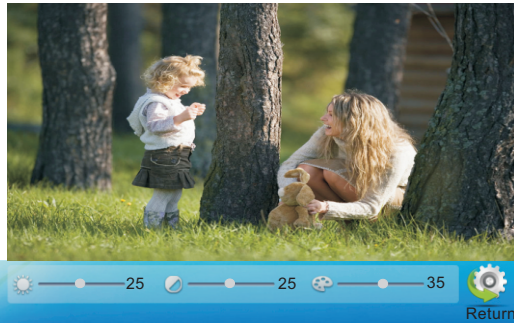

On the color menu, the video color of Door1/Door2/CAM1/CAM2 attributes can be adjusted for the best image quality. Scroll the button “⚙” upwards or downwards to move the cursor to the option “Door1” or “Door2” or “CAM1” or “CAM2”, then press “⚙” to enter the corresponding menu to adjust values of brightness, contrast and chrome depending on the actual conditions.



 — 25 Brightness, values can be set up from 0 to 50, default as 25.

 — 25 Contrast, values can be set up from 0 to 50, default as 25.

 — 35 Chroma, values can be set up from 0 to 50, default as 35.

**[Return]:** Exit the current menu.

## 6. Playback

On main menu, move the cursor to the option “Files”, then press “⚙” to enter the “Files” menu. For the models with SD card, options include “Record files” and “Snapshot files”.

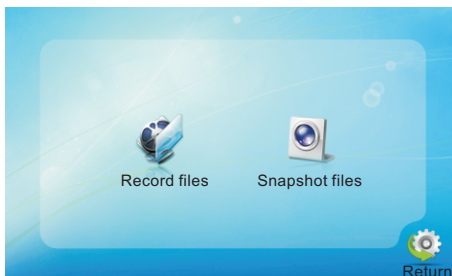

## 6.1 Files – Record files

On “Files” menu scroll the button “⚙” upwards or downwards to move the cursor to the option “Record Files”, press the button “⚙” to enter the “record files list”. Scroll the button to move the cursor to select file to playback. A red list indicates that the list has been selected \_ press the button “⚙”, some tips “Play”, “Delete current file” and “Delete all file” will appear on the right side of the screen. Select “Play” to play back the current file, select “Delete current file” to delete the selected file, and select “Delete all file” to delete all the files stored on the SD card. During playback press the “⚙”, it will switch the current video to the last file or the next file, and press the button “⚙” again to exit. Move the cursor to the option “Return” and press “⚙” to exit the current menu.





## 6.2 Files – Snapshot files

On “Files” menu scroll the button “⚙” upwards or downwards to move the cursor to the option “Snapshot Files”, press the button “⚙” to enter the “snapshot files list”. Scroll the button to move the cursor to select file to playback, a red list indicates that the list has been selected, press the button “⚙”, some tips “Play”, “Delete current file” and “Delete all file” will appear on the right side of the screen. Select “Play” to play back the current file, select “Delete current file” to delete the selected file whether or not, and select “Delete all file” to delete all the files stored on the SD card whether or not. During playback scroll the button “⚙”, it will switch the current video to the last file or the next file, and press the button “⚙” again to exit. Move the cursor to the option “Return” and press “⚙” to exit the current menu.



# Alarm Instructions

CAM1 and CAM2 of this production have each an alarm function. When the trigger terminal and GND is shorted, the alarm is activate, the speaker of the indoor unit rings and continues 120s, during this time, click “ Hang up” to stop alarming and enter the standby mode.

For the models with SD card, the monitor triggers recording or snapshotting (relative to the system settings). The recording time is 120s, during this time, click “ Hang up” to stop alarming and enter the standby mode.

## Connection diagram:

 For applicable header 2 normally closed (NC) or normally open (NO) alarm inputs. 2 camera channels of alarm input without limitations on input type (can either be the normally open type or the normally closed type).

ALM terminal of the alarm detector is connected in parallel with the ALM terminal (The alarm detector shall be supplied by external power supply). Ground terminal of the alarm detector is connected in parallel with the GND terminal of the camera.

For NO alarm inputs, when the GND and ALM are in the connection state, it will trigger the alarm.

For NC alarm inputs, when the GND and ALM are in the disconnect state, it will trigger the alarm.

It applies to any alarm sensor.

