

OWNER'S MANUAL

FOR HOUSEOLD USE ONLY

Please read this document carefully before installing
and/or using your vacuum cleaning system.

SERIAL NO: _____

IMPORTANT SAFETY INSTRUCTIONS

When using an electrical appliance, basic precautions should always be followed, including the following.

Read all instructions before using this appliance

WARNING

To reduce the risk of fire, electric shock, or injury:

1. Do not leave appliance when plugged in. Unplug from outlet when not in use and before servicing.
2. Do not use outdoors or on wet surfaces.
3. Do not allow to be used as a toy. Close attention is necessary when used by or near children or infirm persons. This appliance is not intended for use by persons (including children) with reduced physical, sensory or mental capabilities, or lack of experience and knowledge, unless they have been given supervision or instruction concerning the use of the appliance by a person responsible for their safety.
4. Use only as described in this manual. Use only manufacturer's recommended attachments.
5. Do not use with damaged cord or plug. If appliance is not working as it should, has been dropped, damaged, left outdoors, or dropped into water, return it to a service center.
6. Do not pull or carry by cord, use cord as a handle, close a door on cord, or pull cord around sharp edges or corners. Do not run appliance over cord. Keep cord away from heated surfaces.
7. Do not unplug by pulling on cord. To unplug, grasp the plug, not the cord.
8. Do not handle plug or appliance with wet hands.
9. Do not put any objects into openings. Do not use with any opening blocked; keep free of dust, lint, hair, and anything that may reduce air flow.
10. Keep hair, loose clothing, fingers, and all body parts away from openings and moving parts.
11. Do not pick up anything that is burning or smoking, such as cigarettes, matches, or hot ashes.
12. Do not use without dust bag and/or filters in place.
13. Turn off all controls before unplugging.
14. Use extra care when cleaning on stairs.
15. Do not use to pick up flammable or combustible liquids such as gasoline or use in areas where they may be present.
16. Connect to a properly grounded outlet only. See Grounding Instructions.

TABLE OF CONTENTS

Preface	6
Schematic – M40 & M50	6
Schematic – Other Models	7
INSTALLATION	
Unit Installation	8
Dos & Don'ts	9
Muffler Installation	12
Electric Connections	13
Grounding Instructions	14
Low Voltage Connections	15
OPERATING INSTRUCTIONS	
Hose Hook-up & Inlets	16
LED Indicator	17
Attachments	18
MAINTENANCE	
Motor	20
Maintenance – with bag	21
Converting the vacuum unit	22
Maintenance – without bag	23
TROUBLESHOOTING	
General Information	24
Decrease in suction strength	25
Vacuum will not start	27
Vacuum will not stop	28
WARRANTY INFORMATION	
Limited Lifetime Warranty	29
Warranty on Attachments	30
WEEE Directive	31

PREFACE

Your new IST central vacuum system was designed and manufactured in Blainville, Quebec, by the largest central vacuum cleaner manufacturer in Canada. With over forty five years of experience in the industry, we provide a high-quality product, and guarantee your complete satisfaction. Our extensive network of qualified professionals ensures first quality service near you. Contact us to find your IST authorized service center.

1. Circuit Breaker
2. Low Voltage Connector (M70 & 80 with LED)
3. Serial Number
4. Air Intake
5. Air Exhaust
6. Muffler (optional)

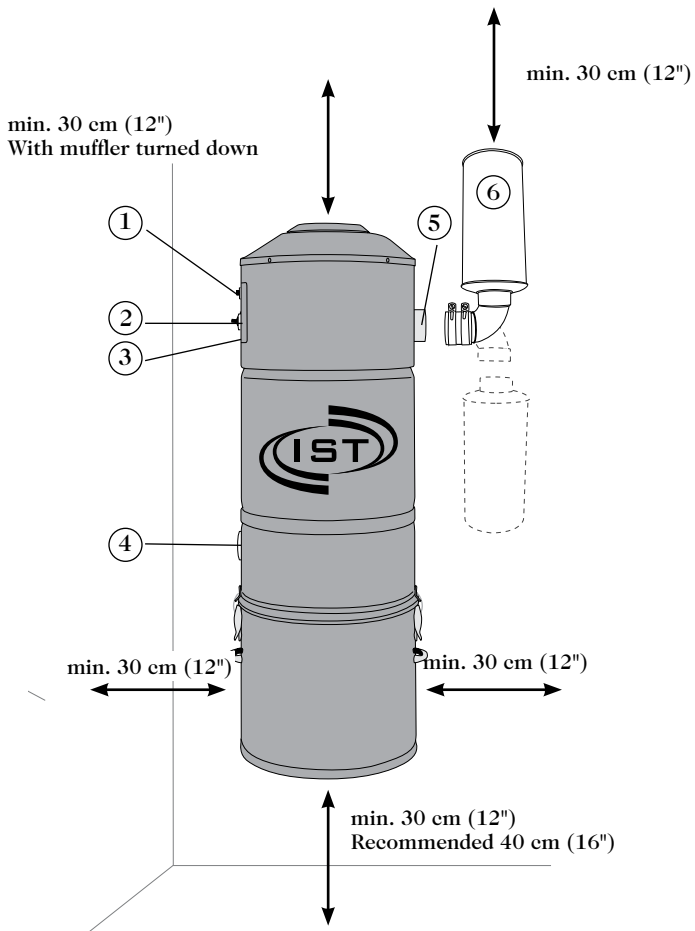

Model may differ from the illustration.

UNIT INSTALLATION

Using the mounting plate provided with your vacuum cleaner, secure the unit to the wall (**figure 1**), at a height allowing easy access for maintenance of the filters, dirt receptacle and/or bags (see page 7).

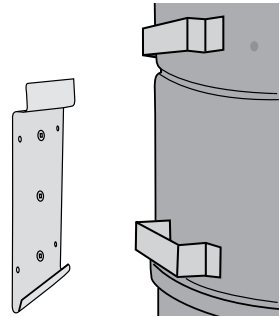

figure 1

The connections to the piping system will require some basic tools: a mitre box and small saw or a pipe cutter (**figure 2**). See pages 9 and 10 for general instructions pertaining to the preparation of PVC pipes. To simplify matters, installation kits, including necessary fittings, pipes, glue and wiring, as well as a detailed instructions booklet, are available from IST service centers.

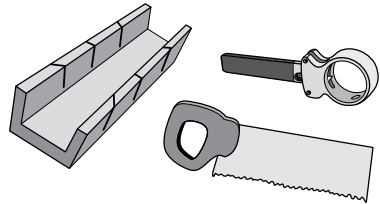

figure 2

Contrary to all other connections in the piping system, **do not glue the last fitting to your unit**. IST central vacuums are equipped with an adjustable air intake valve (**figure 3**), which does not require glue. An airtight fit is achieved with the screw-type adjustment on the fitting itself.

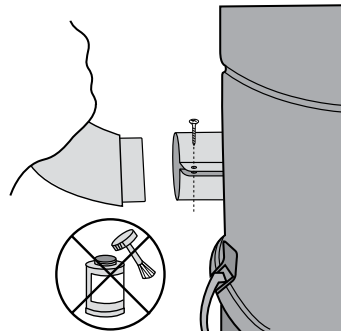
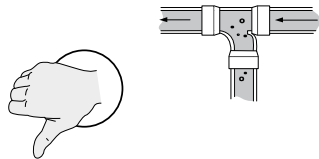
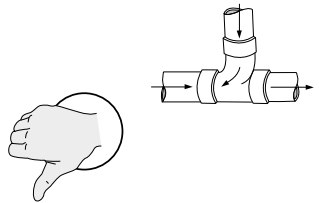
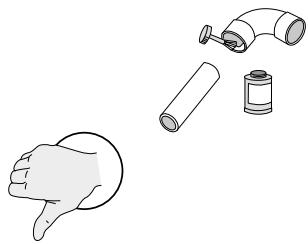
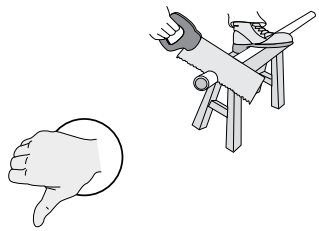
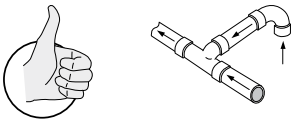
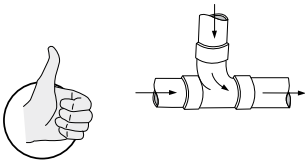
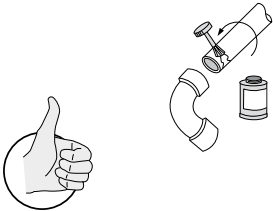
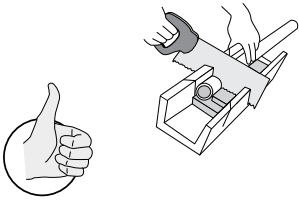
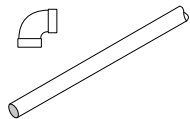
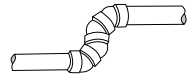
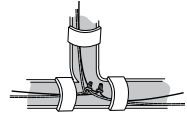
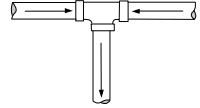
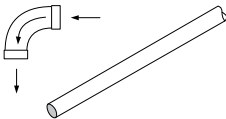
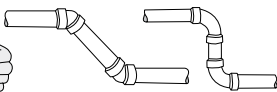
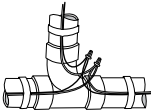
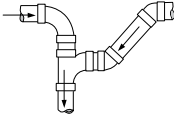

figure 3

INSTALLING CONDUITS



DOS & DON'TS



INSTALLING INLETS

When installing your vacuum inlets, we recommend that the principle of electric polarity be taken into account. Ensure that the wire connected onto contact A on inlet 1 is the same as that connected to contact A on inlet 2, and so on. Do not cross, reverse or interchange wires.

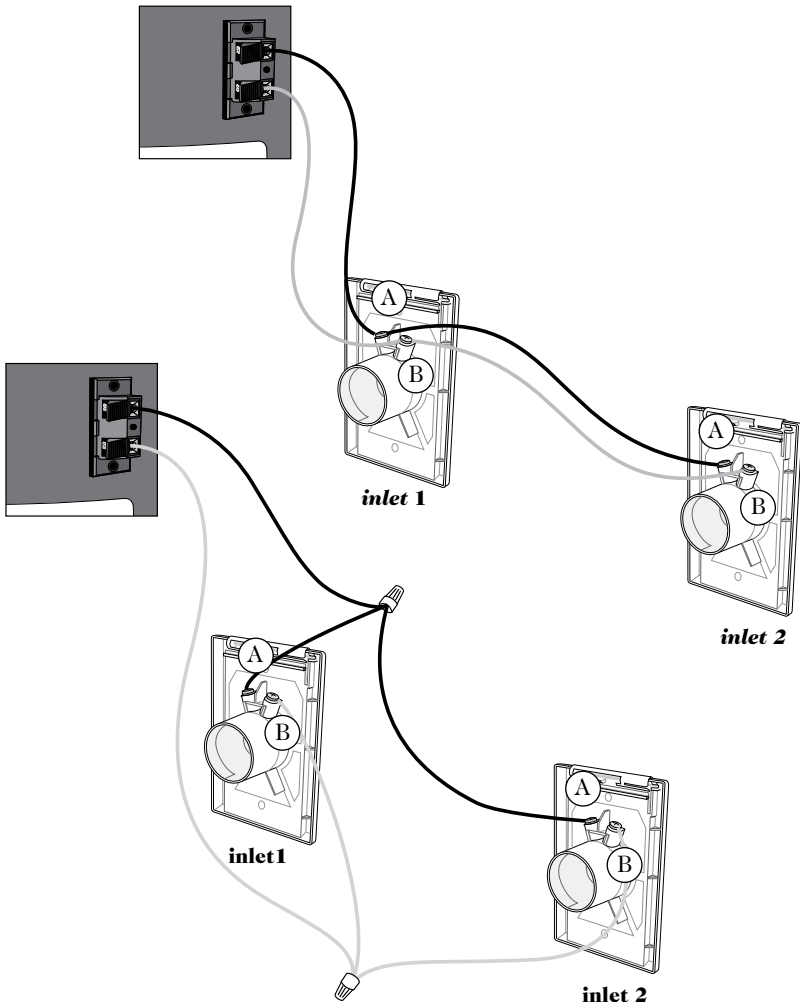

MUFFLER INSTALLATION (OPTIONAL)

1. Insert the rubber coupling on the vacuum air exhausts.
2. Using a Phillips screwdriver, tighten the clamp collar to ensure adequate sealing.
3. Insert the 90° elbow into the rubber coupling, and tighten then clamp collar as per instructions in step 2.
4. Apply ABS glue to the 90° elbow and insert muffler.

- A. Rubber coupling
- B. 90° elbow
- C. Muffler
- D. Air Exhaust

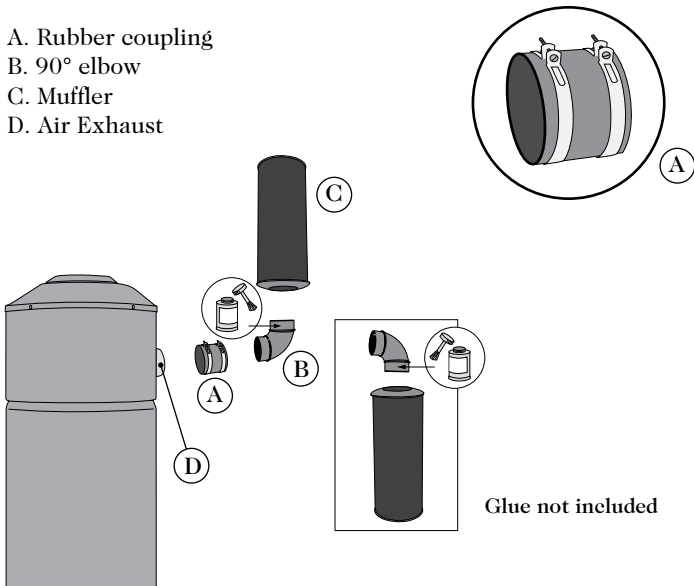

Model may differ from the illustration.

ELECTRIC CONNECTIONS

There should be an electric outlet within 1 meter (3 feet) of your central vacuum unit. Once the appliance is installed in a suitable location, connect your power unit to an electric outlet on an ***dedicated* grounded circuit***. Do not use extension cords or modify the length of your vacuum cleaner's power cord.

DEDICATED* GROUNDED CIRCUIT

- **North America**

120 V / 240 V all models : 15 A

- **European continent and others**

220 V / 240 V All models

Your central vacuum cleaner has a thermal safety device or a circuit breaker to protect against any over voltage or electrical defect. If that protection should fail, contact your authorized service center.

* Please reserve a circuit breaker dedicated only to the connections for your central vacuum.

If you find that installing your vacuum cleaner is too difficult, ask your service center to install it for you. When in doubt, it is better to have the work done by a professional and ensure that the unit is properly installed. Any installation that does not comply with the specified norms could alter or invalidate the warranty.

GROUNDING INSTRUCTIONS

This appliance must be grounded. If it should malfunction or breakdown, grounding provides a path of least resistance for electric current to reduce the risk of electric shock. This appliance is equipped with a cord having an equipment-grounding conductor and grounding plug. The plug must be inserted into an appropriate outlet that is properly installed and grounded in accordance with all local codes and ordinances. No adaptor should be used with this appliance.

WARNING

Improper connection of the equipment-grounding conductor can result in a risk of electric shock. Check with a qualified electrician or service person if you are in doubt as to whether the outlet is properly grounded. Do not modify the plug provided with the appliance – if it will not fit the outlet; have a proper outlet installed by a qualified electrician.

120 V MODELS

This appliance is for use on a nominal 120 V circuit, and has a grounded plug (**figure 4**). Make sure that the appliance is connected to an outlet having the same configuration as the plug. No adaptor should be used with this appliance.

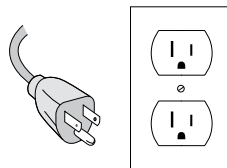
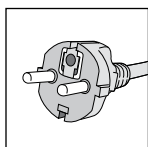

figure 4

220 V/240 V MODELS

This appliance is for use on a circuit having a nominal rating more than 120 V and is factory-equipped with a specific cord and plug to permit connection to a proper electric circuit. Make sure that the appliance is connected to an outlet having the same configuration as the plug. No adaptor should be used with this appliance. If the appliance must be reconnected for use on a different type of electric circuit, the reconnections should be made by a qualified professional.



Type C

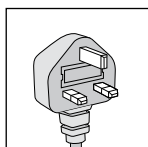

Type G

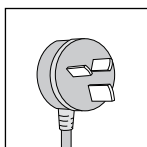

Type H

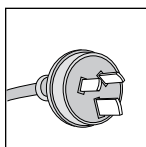

Type I

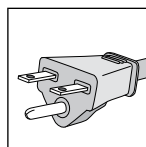

Nema 6-15 R

LOW VOLTAGE CONNECTIONS

Connect the low voltage wires to the low voltage inlet on your unit.

To do so:

1. Strip wires over 1 cm (½ inch) (**figure 5**).
2. Gently press on the toggle to open the connector (**figure 6**).
3. Insert stripped wire (**figure 7**).
4. Release toggle to secure wire in connector (**figure 8**).
5. Repeat for second wire.

To disconnect:

1. Gently press on the toggle to open the connector.
2. Remove low voltage wire from connector.

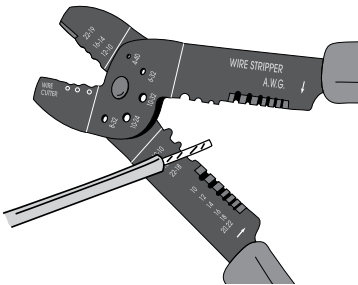

figure 5

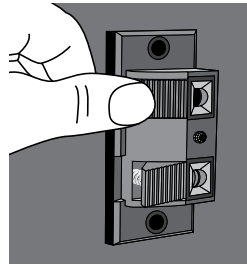

figure 6

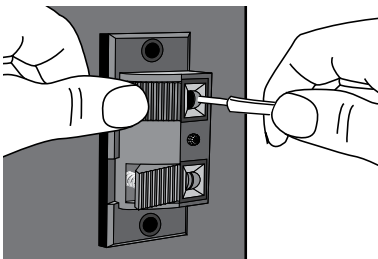

figure 7

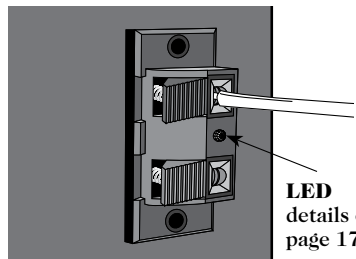

figure 8

HOSE HOOK-UP & INLETS

Before operating your central vacuum...

Please verify that it is properly connected to the piping system, and to a grounded electrical outlet, and that the low voltage wires are connected to the unit (see pages 8 to 15). Then read the complete owner's manual and proceed with a quick verification of your unit's installation:

- Check filter and bag to be sure they are properly installed.
- Check rubber seals in each vacuum inlet.

To start your central vacuum, simply insert the hose in the vacuum inlet of your choice. Please ensure that the tab on the hose end is properly lined up with the slot in the inlet opening (**figure 9**). If your hose handle has an integrated on/off switch, simply slide the switch to the "on" position.

Do not try to open another inlet while your system is in operation, as it may damage the inlet's rubber seal.

- While the hose is still plugged into one inlet and the system is operational, check other inlets for leaks.
- Plug the hose alternatively into each vacuum inlet, to ensure that each one works properly.

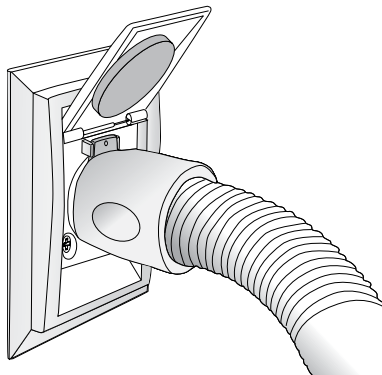

figure 9

LED INDICATOR

S7 & S8 MODELS

LED – On low voltage connector

Steady green – indicates unit is connected to a power source.

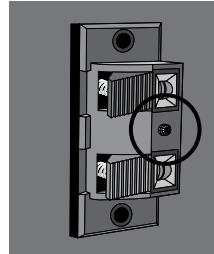

ATTACHMENTS

OVAL DUSTING BRUSH

Use just about anywhere: on lamps & lamp shades, blinds, shelves, decorative trims.



UPHOLSTERY BRUSH

With removable bristles, use to clean all upholstered furniture such as sofas, chairs, and mattresses.



CREVICE TOOL

Use in narrow spaces, nooks and crannies, such as heating ducts, between sofa cushions, and between window panes.

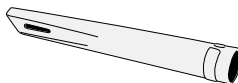

FLOOR BRUSH

For use on all types of flooring: hardwood, ceramic or even small carpets.

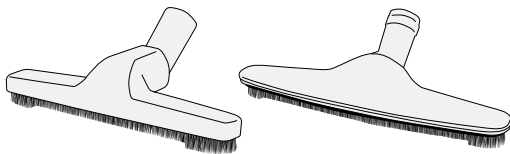

CARPET BRUSH

Specially designed for small carpets and area rugs, it cleans down deep.

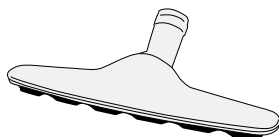

HOSE HANGER

In addition to conveniently holding your hose, it's specially designed to allow the storage of your floor brush on the telescopic wand, without crushing the brush bristles.

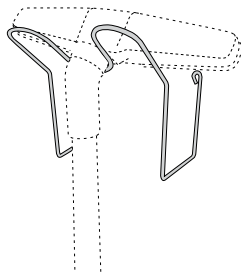

TELESCOPIC WAND

It's easily adjusted to the desired height. Simply depress the button, slide the wand to the desired length, and release the button for it to lock into position. Convenient button-lock mechanisms prevent the wand from slipping off the hose handle.

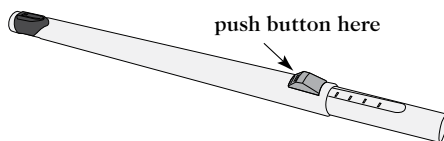

ATTACHMENT HOLDER

Made of durable vinyl, it conveniently holds all your accessories. Hang it on your hose holder, to keep all accessories at hand.

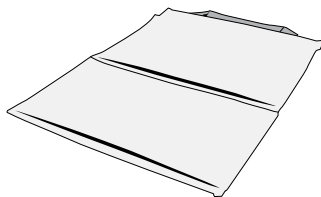

MOTOR

Please note that ***IST motors do not require lubrication***. Each motor contains two carbon brushes which will wear normally, and may eventually require replacement. For warranty purposes, this should be done by an authorized service center. The brush's life is affected by the number of hours of use, frequency of start-ups and shut-downs, humidity, altitude, and temperature. In order to avoid damage to the motor itself, brushes should be replaced before they are completely worn out. We therefore recommend that you have your unit and motors inspected by a service center every 5-6 years.



USE WITH BAG

Change the bag when the one in place is full. Frequency will depend on the use of the unit.

1. To access the bag, unlatch the two clips and remove the dust receptacle (**figure 13**).
2. Remove the used bag and seal bag opening (adhesive seal provided on each bag). Discard used bag.
3. Install the new bag, ensuring the tabs on the bag adaptor are aligned with the slots in the bag collar (**figure 14**).
4. Ensure adequate sealing by inserting bag as far as the retention ring. (**figure 15-A**). Rotate bag 20° (**figure 15 - B**) to ensure tabs on bag adaptor are no longer aligned with the slots in the bag collar.
5. Replace dust receptacle and seal by latching both clips.

Use only genuine ITL replacement bags. Failure to do so could void the warranty on your vacuum unit.

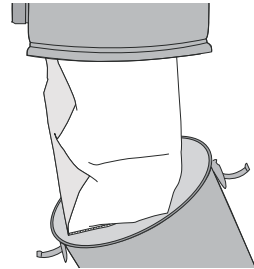

figure 13

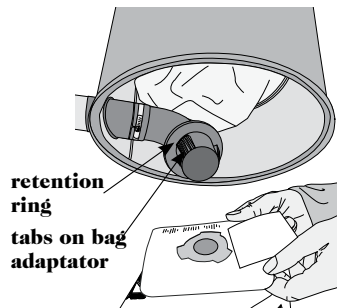

figure 14

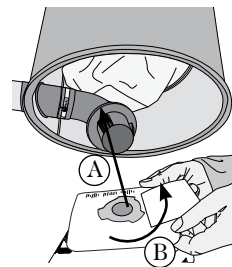

figure 15

Parts number :
Models S5, S7, S8 – TDSAC23N

CONVERTING THE VACUUM UNIT



USE WITHOUT BAG

Your IST central vacuum unit was designed for use with or without disposable bag. Though it is sold with a bag installed, it can easily be removed, and the unit modified for use without disposable bags.

1. To access the bag, unlatch the two clips and remove the dust receptacle (**figure 6**).
2. Remove the used bag (**figure 17**). If it has been used, seal its opening with the self-adhesive flap on the bag collar (see instructions on the bag). Discard the used bag. If the bag was not utilized, you may wish to store it for later use.
3. Remove the two screws from the adaptor. (**figure 18**).
4. While grasping both the bag adaptor and the fitting, turn and remove the bag adaptor (**figure 19**). Store these parts for future use, if so desired.
5. The vacuum unit is now ready for use without bags.

Note: this procedure is reversible at any time.

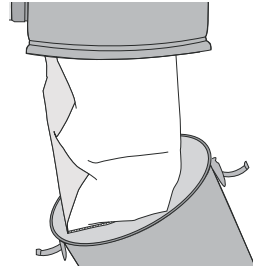

figure 16

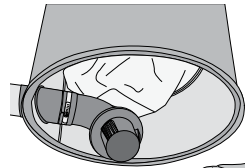

figure 17

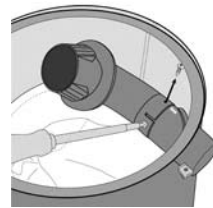

figure 18



figure 19



USE WITHOUT BAG

We recommend you empty the dust receptacle and clean the permanent filter at least each season, depending on use of your central vacuum.

1. To empty the dust receptacle:

Disconnect the unit from the electric outlet. Unlatch the two clips, remove the receptacle (**figure 20**), and empty into an appropriate container.

2. To clean the permanent filter (**figure 21**):

- Do not remove the filter
- Wrap the filter and the lower portion of the unit body within a large plastic bag. Hold it tightly around the unit with one hand.
- With your other hand, gently shake the filter.
- Wait a few seconds for the dust to settle before removing the plastic bag.

3. Replace the dust receptacle and seal with the help of the two clips.

4. Reconnect the unit to the electric outlet.

Note :

Should the filter become stained, or emit an unpleasant odor, it may be washed in cold water (without bleach). Rinse and dry well before replacing. Do not tumble dry.

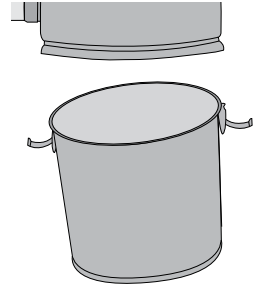

figure 20



figure 21

GENERAL INFORMATION

If the vacuum unit does not work, check the fuse or breaker on the unit and/or in the electrical panel in your home, and replace any defective part(s) as deemed necessary. Please verify that the unit has been installed properly, according to the instructions in this manual.

Your vacuum cleaning system is designed to collect everyday dry matter (dust). It is approved by authorized testing agencies for dry use only. Do not use on wet surfaces.

Should you accidentally vacuum liquids, immediately unplug the unit from the electric outlet, then empty and wipe the dust recipient with a dry cloth. Then operate the system from the vacuum inlet through which you vacuumed the liquid, in order to eliminate all moisture in the piping system.

We strongly recommend against vacuuming abrasive materials such as cement, plaster and gyproc dust. This fine dust could work its way into the motor, causing considerable damage. Should you do so inadvertently, immediately clean the filters and, as a precautionary measure, contact your authorized service center to determine the extent of the damage to the unit.

Remember that in order for your warranty to remain valid, maintenance of the motor and repairs to the unit itself must be carried out by an authorized service center, using original Trovac parts.

TROUBLESHOOTING

PROBLEM	POSSIBLE CAUSE	CORRECTIVE ACTION
Decrease in suction strength	Dirt recipient / Bag is full	Empty dirt recipient / change bag (see page 21 to 23).
	Dirt recipient is not properly attached	Check clamps holding dirt recipient, to make sure they are tight, and dirt recipient is aligned.
	Open vacuum inlet	Close all vacuum inlets not in use.
	Exhaust line is clogged	Verify that no object is blocking the exhaust.
	Blocked hose	Plug the handle end of the hose into the suction inlet, thus reversing the suction in the hose. Cover the gap around the handle, to ensure suitable suction strength, and ensure contact with inlet contacts to start the unit. This should clear the hose.

TROUBLESHOOTING

PROBLEM	POSSIBLE CAUSE	CORRECTIVE ACTION
Decrease in suction strength (cont.)	Obstruction in the piping system	Remove the screw from the air intake connector, to free the central vacuum unit from the piping system (see figure 3 on page 8). Start the unit by plugging the hose into a vacuum inlet. By placing your extended hand over the air intake opening on the unit, check the suction strength on the unit itself. If suction strength is normal, the obstruction is in the piping system. If suction strength is diminished or completely absent, have the unit checked by an authorized service center.

If none of these suggestions restore suction strength, contact your authorized service center.

TROUBLESHOOTING

PROBLEM	POSSIBLE CAUSE	CORRECTIVE ACTION
Vacuum will not start	The electrical power is not connected properly	Ensure that the power cord is plugged into a dedicated grounded electrical outlet, according to specifications on pages 13 and 14.
	Low voltage wire not connected properly	Verify the low voltage wires, make sure they are properly inserted into the low voltage inlet, as per instructions on page 15.
	Faulty vacuum inlet	Start the vacuum unit from other inlets in your home, to identify the defective inlet.
	Unit circuit breaker is off	Press the reset button to reset the unit circuit breaker. If unit restarts and automatically shuts off shortly after, contact an authorized service center.
	In-house circuit breaker is off	Reset the circuit breaker in your electrical panel. Verify that your central vacuum unit is connected on a dedicated grounded circuit (see pages 13 and 14).
	Defective on/off hose	Turn the hose ¼ turn in the vacuum inlet. If unit starts, have the vacuum hose checked by a certified service center.

TROUBLESHOOTING

PROBLEM	POSSIBLE CAUSE	CORRECTIVE ACTION
Vacuum will not stop	Hose improperly inserted into vacuum inlet	Ensure that the hose end is properly placed in the vacuum inlet: the tab on the hose should fit into the slots on the inlet, to ensure adequate contacts for the hose switch to function (see page 16).
	Defective on/off hose	If the hose is properly placed in the vacuum inlet, and the unit continues running despite the fact that the hose switch is in the “off” position, have the hose checked by a service center.
	Low voltage wire not connected properly	While vacuum is on, unplug low voltage wires from unit. If vacuum stops, there’s a faulty low voltage wire. Contact your installer or authorized service center.

WARRANTY INFORMATION

This warranty is valid for domestic use only.

LIMITED LIFETIME WARRANTY

Your IST vacuum system is protected by a lifetime warranty. We guarantee that the unit canister will be exempt of any material or manufacturing defect. This warranty is valid from the date of purchase, for as long as you are the original owner, and the system remains at its original place of installation.

The motors and electrical components are guaranteed according to conditions below:

IST Warranty Motors and Electrical Components

S5 & S7	5 years
S8	10 years

In order to maintain your warranty, all repairs must be made by an authorized IST service center, with original Trovac parts. Failure to do so could void the warranty.

This warranty excludes normal wear and tear of certain parts such as filters, damages caused (according to IST) by abusive use (ex.: drywall dust, water, etc.), commercial use, the lack of appropriate maintenance, inadequate installation, negligence, natural disasters, accidents, and acts of God.

WARRANTY INFORMATION

ONE YEAR WARRANTY ON ATTACHMENTS

Your attachments are guaranteed for one year, subject to certain conditions. If during this one year period, an accessory presents a manufacturing defect, return it to the nearest authorized IST service center along with a copy of your invoice (clearly indicating the attachments purchased), and we will repair or replace the part according to the conditions of the warranty. This warranty does not cover normal wear and tear of components such as: belts, brushes, rollers and their components, nor abusive use. It is valid only for normal domestic use.

This warranty is valid for domestic use only. This warranty is not a modification but an addition to warranties required by law. ***Any claim relative to this warranty must be accompanied by the original invoice.*** Any changes or modifications made to the product may invalidate this warranty. Transportation and service calls are excluded . This warranty is non transferable.

Keep all payment records (bill of sale, delivery slip). The date on these records establishes the warranty period. Should warranty service be required, you must show proof of purchase. If proof of purchase cannot be supplied, the warranty period will be determined from the date of manufacture of the product.

IST shall not be held responsible for any consequential, incidental, or special damages arising from the use of this central vacuum.

Warranty may vary depending on country.

Important Environmental Information – European Economic Area only

This appliance has been assessed in accordance with the European Parliament Directive on Waste Electrical and Electronic Equipment, usually referred to as the WEEE Directive.

The WEEE Directive requires that the appliance be disposed of at the end of its useful life in an environmentally responsible manner. Parts and materials should be re-used or re-cycled in order that the use of new resources and amount of waste going for landfill can be minimised.

The WEEE Directive stipulates that the supplier should collect the used item without cost to you. Please inform the supplier of your wish to have the old appliance collected when ordering the replacement.

If you wish to dispose of the appliance yourself, do not mix it with unsorted municipal waste. The crossed-out wheeled bin symbol on the unit label (**figure 22**) indicates this requirement. You must ensure that the appliance is disposed of at an authorised treatment facility. Details can be obtained from your local council.

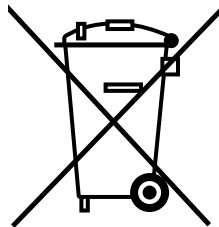
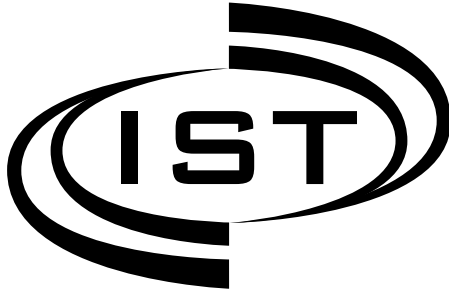

figure 22



WWW.INTRASONICTECHNOLOGY.COM

HEAD OFFICE

610 Presidential Drive
Suite 104
Richardson, Texas 75081
877-435-0670